

## CRYOMAK – THE OVERVIEW OF CRYOGENIC TESTING FACILITIES IN KARLSRUHE

Jan Sas<sup>1)\*</sup>, Klaus-Peter Weiss<sup>1)</sup>, Nadezda Bagrets<sup>1)</sup>

<sup>1)</sup> Karlsruhe Institute of Technology, Institute for Technical Physics, Eggenstein-Leopoldshafen, Germany

Received: 04.12.2015

Accepted: 07.12.2015

\*Corresponding author: e-mail: jan.sas@kit.edu, Tel.: +49 721 608 24164, Karlsruhe Institute of Technology, Institute for Technical Physics, Hermann-von-Helmholtz-Platz 1, 763 44 Eggenstein-Leopoldshafen, Germany

### Abstract

Since the field of cryogenic applications and testing has become very valuable, demand for material specification and improvements in this area has increased as well. One of the possibilities for the characterisation of cryogenic materials with a wide range of tests can be found at the Cryogenic Material Test Facility Karlsruhe (CryoMaK), within the Institute of Technical Physics (ITEP) at the Karlsruhe Institute of Technology (KIT). Skills, knowledge and best practices, related to cryogenic testing, have been developed by CryoMaK for over 30 years. The facility provides a possibility of measuring mechanical, electromechanical and thermal properties of materials and components. Further it is possible to measure tensile force (F), critical magnetic field ( $B_c$ ) and critical current ( $I_c$ ) to examine the quench behaviour of superconducting current cables.

This article describes new facilities as well as possibilities in relation to testing in CryoMaK.

**Keywords:** low temperatures, mechanical properties, electromechanical properties, thermal properties, superconductivity

### 1 Introduction

During the last decades the field of cryogenic applications down to 77K or even 4.2K is growing continuously. Not only focusing on scientific topics, but also in industrial or commercial interest.

Just to give some examples, Liquefied Natural Gas (LNG) is today common for transportation, cooled to temperatures of about 110K [1, 2]. Further, space applications also demand the need to reach low temperatures to simulate the boundary condition experienced in space [3, 4]. There are even more cryogenic applications in a various fields like medicine [5], automobile [6] and tool hardening [7].

As a major field of cryogenic applications the superconducting state of material composites, e.g. NbTi, Nb<sub>3</sub>Sn, MgB<sub>2</sub> or YBa<sub>2</sub>Cu<sub>3</sub>O<sub>x</sub>, allows to build various components. Electric cables [8], magnets [9], transformers [10], or so-called fault current limiters [11] are to name. All these components have the need for cooling by cryo-coolers or by LN<sub>2</sub> at least to 77K if not to 4.2K using LHe [12].

However, during design and construction the engineering task has to be done under consideration of the material properties at operational temperature. Therefore, material tests from room temperature down to 4.2K are necessary. Materials of interest are structural (steel, reinforced plastic, etc.) as well as functional materials (superconductors, insulation material, etc.).

## 2 Mechanical properties

The main topic of CryoMaK is characterization of mechanical properties and components at cryogenic temperatures within the range – RT to 4 K. Beside basic research, the work is focused on the measurements at cryogenic temperatures in collaboration with external companies, mainly within the field of the ITER project. The knowledge and skills achieved in testing are used for the creation of new standards with the cooperation of the DIN (Deutsche Institut für Normung) and the IEC (International Electro-technical Commission). Usually perform standard tensile, fatigue and fracture toughness tests as described in the **Table 1**. However, if necessary, our facilities can be used for the measurement of non-standard tests for the needs of our suppliers.

The possible methods of cryogenic testing, are summarized in the **Fig. 1**. They are divided in dynamic and static test setups. All of these machines are equipped with cryostats for low temperature. As already mentioned these machines are used for the measurement of specimens and components of metal and non-metal materials. In relation to force we can measure on the scale from 25 kN to 650 kN depending on the machine.

There are a number of facilities in operation, including new devices, such as *MTS 100 kN*, *Galdabini 450 J*, *INSTRON CEAST 9350* and *INNOVATEST NEXUS 4302* which came into operation in CryoMaK in 2014.

Specimen machining, as well as component production, for tests are done within the KIT workshop, having a long-term experience for cryogenic application.

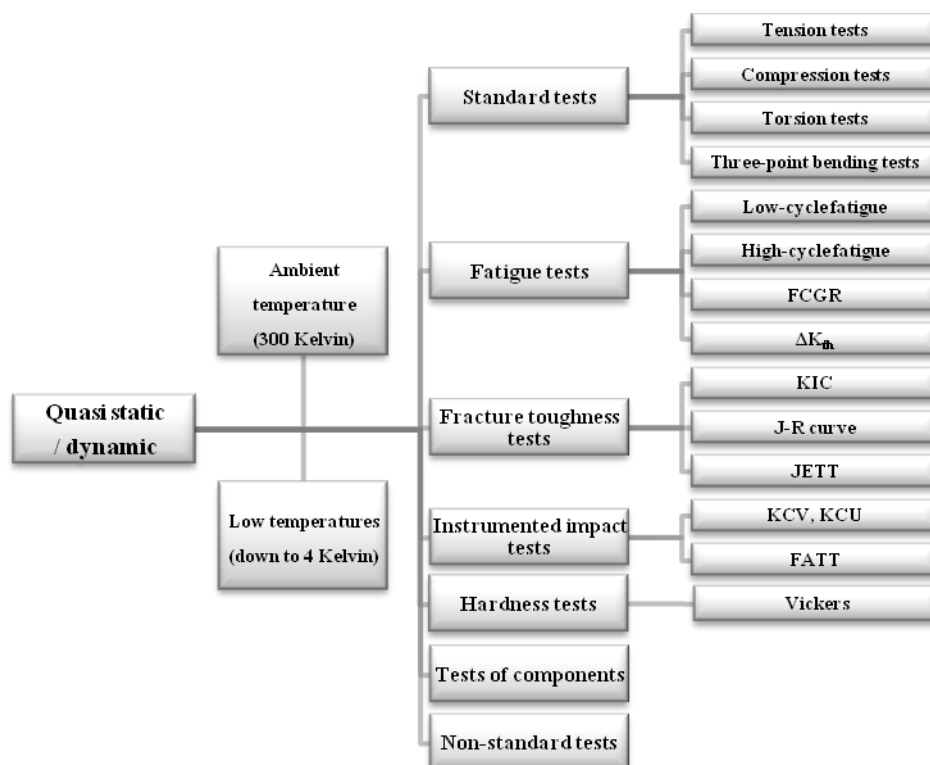

**Fig. 1** Available mechanical tests at CryoMaK facilities

**Table 1** CryoMaK facilities for testing mechanical properties at low temperatures

| Test facility                      | Maximal force<br>+/- kN        | Temperature<br>K | Test type   | Standards*           |
|------------------------------------|--------------------------------|------------------|---|----------------------|
| MTS25                              | 25                             | RT → 7           | Standard tests<br>Fatigue tests<br>Fracture<br>toughness tests<br>Tests of<br>components<br>Non-standard<br>tests | DIN EN ISO<br>6892-1 |
| MTS50                              | 50                             | RT → 77          |   | ASTM E8              |
| MTS100                             | 100                            | RT → 4.2         |   | DIN ISO 15579        |
| ATLAS                              | 650                            | RT → 4.2         |   | ASTM E 1450          |
| TORSION                            | 160 – axial<br>1000 Nm-torsion | RT → 4.2         |   | DIN ISO 19819        |
| PHOENIX                            | 100                            | RT → 4.2         | JIS Z 2277  | ASTM E 466           |
| GALDABINY<br>INSTRON<br>CEAST 9350 | 450J<br>752J                   | RT → 77<br>RT    | Instrumented<br>Impact Tests  | JIS Z 2283           |
| INNOVATEST<br>NEXUS 4302           | 30Kgf                          | RT               |   | ASTM E 606           |
|                                    |                                |                  | Standard tests<br>Non-standard<br>tests   | ASTM E 647           |
|                                    |                                |                  |   | JIS Z 2284           |
|                                    |                                |                  |   | ASTM E1820           |
|                                    |                                |                  |   | ISO 148              |
|                                    |                                |                  |   | ASTM E23             |
|                                    |                                |                  |   | JIS Z 2202           |
|                                    |                                |                  | Hardness Test   | ISO 6507-2           |
|                                    |                                |                  |   | ASTM E92             |

\* These are only examples of standards. Tests according to a variety of other standards are performed as well.

### 3 New CryoMaK facilities

#### 3.1 MTS 100 Landmark

The *MTS 100 Landmark* facility is one of testing facilities in CryoMaK to perform different kinds of tests, according to international accepted standards on the temperature range from RT down to 4 Kelvin, as it is described in the **Table 1**. The MTS Landmark platform uses servohydraulic technology for a full spectrum of static and dynamic material test requirements. The facility can reach the maximum load capacity up to 100 kN which can be combined with the maximum frequency 40 Hz. Linear elastic and elastic-plastic fracture toughness testing can be readily configured by the MTS software. What is more, the system load frame can be used for both pre-cracking and fracture testing.

The integration of the cryostat to the *MTS 100 Landmark* (see **Fig. 2**) will be done in 2016, comparable to the existing MTS 25 cryogenic system, operating successfully since more than 20 years. With this it is possible to perform mechanical tests at cryogenic conditions, comparable to operation conditions encountered by the materials under investigation. The cryostat is used for the cooling down process of two stage cooling procedure with a vacuum shield. The cooling down process uses two chambers, first for cooling the chamber to temperature down to 77 Kelvin and the second is used for cooling down to 4.2 Kelvin, facilitating a closed tube system for cooling liquids nitrogen and helium, respectively. The benefit of this kind of cooling process is that a specimen is not inserted in a liquid (LN<sub>2</sub>, LHe), producing bubbles influencing the signal of extensometers.

For the length change of material properties during mechanical tests, clip-on extensometers are used. These extensometers, produced by CryoMaK, can be adapted in a wide range according to tested materials and components. Within CryoMaK different kinds of extensometers are in use, details of the extensometers are described elsewhere [13-15].



**Fig. 2** MTS 100 Landmark with the cryostat (RT → 4K)

### 3.2 Devices for the measurements of Instrumented Impact Tests

Impact tests are designed to measure the resistance of a material to failure with an almost instant applied force. The test measures the impact energy, or the energy absorbed prior to fracture. The most common methods of measuring impact energy are the Charpy and Izod tests. Tests can be used on metals, polymers, ceramics and composites. It is most commonly used to evaluate the relative toughness or impact toughness of tested materials. The Charpy test is often used in quality control applications, being a fast and economical test. Mostly it is used in cryogenics as a comparative test rather than a definitive test.

Additionally it is possible to measure the time resolved instrumented impact test according to ASTM E23 for a wide range of materials in the temperature range from RT down to 77 Kelvin, as it is shown in the **Fig. 3**.

The impact energy in the Charpy test is measured with a high quality digital measurement system, using *Galdabini 450J*, which can perform in the temperature range from RT down to 77K. Instron Ceast 9350 is used only for the room temperature, but in the near future, it is planned to install the cryostat with temperature range from RT down to 4 K.



**Fig. 3** Charpy Impact Test devices (left: Galdabini 450, right: Instron Ceast 9350)

Specimen selection depends on the type of a testing material, as it is shown in the **Fig. 4**. Sharper and deeper notches are necessary to be machined in ductile materials, or when low testing velocities are used. The *CNB-35* hand operated Charpy-Notch-Broaching machine is used for the CryoMaK laboratory, which is producing small series of testing pieces of metals (stainless steel, copper, aluminium...) or non-ferrous materials.

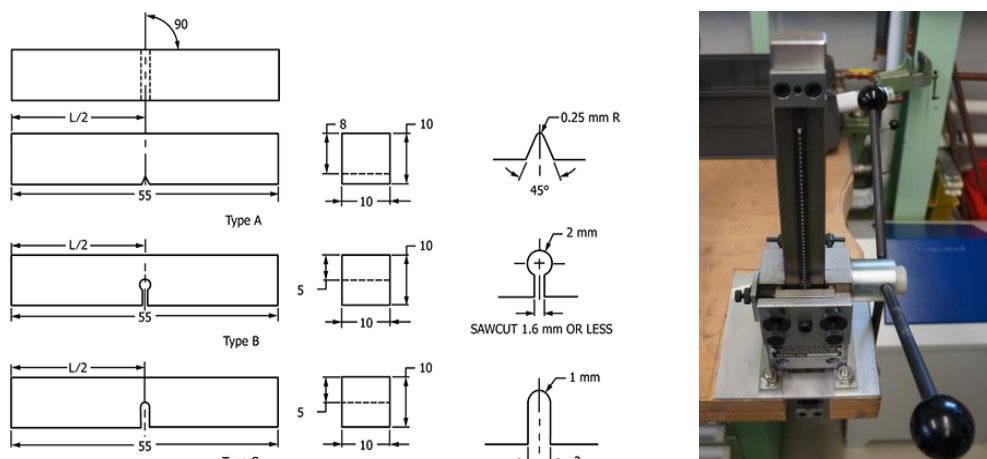

**Fig. 4** Charpy Impact Test specimens of types A, B and C (on the left) and CNB-35 machine (types A and B - on the right)

### 3.3 INOVATEST NEXUS 4302

The measurement of hardness is measured with the device *INOVATEST NEXUS 4302* (Micro-Vickers Hardness Testing System) at room temperature with available configurations as it is shown on the **Table 2**. The tester has a 4-position turret, which can be customized by using different indenters, lenses and stages. The application and removal of the test force is fully automatic, as well as the positioning of the indenter and the positioning of the pre-determined lens. The result is a flawless absolute vibration free operation while reducing the operator's efforts to a minimum. Hardness can be measured on the following standards: ISO 12100:2010, En 60204-1:2006+A1:2009, EN 61326-1:2006.

**Table 2** Available configurations of INOVATEST NEXUS 4302

| Measured force<br>K/gf | 0,2  | 0,3 | 0,5 | 1    | 2 | 2,5 | 3    | 4 | 5 | 10 | 20 | 30 |
|------------------------|------|-----|-----|------|---|-----|------|---|---|----|----|----|
| Lens                   | 10x  |     |     | 20x  |   |     | 40x  |   |   |    |    |    |
| $\mu\text{m}$          | 5,73 |     |     | 0,03 |   |     | 0,04 |   |   |    |    |    |

## 4 Material properties

The CryoMaK laboratory offers a chemical analysis expertise for determining material composition and the element analysis. Experience to analyse different kinds of metals exists. The *Bruker Q4 Tasman 130* is used for the measurement of elements, based on the optical emission spectrometer (OES), determined by an advanced CCD, as it is shown in the **Fig. 5**. The facility is used to support material selection, material verification and the failure analysis research. Chemical analysis techniques include the sparking OES database – for the bulk elemental analysis of steel, stainless steel, copper, aluminium, titanium and nickel alloys. The measurement is done under argon gas atmosphere.

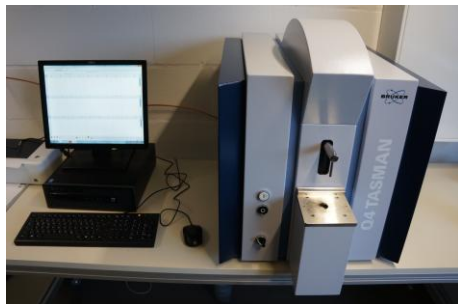

**Fig. 5** Optical emission spectrometer - Bruker Q4 TASMEN 130

## 5 Electromechanical properties

Regarding to electromechanical properties of superconductor strands and cables the FBI facility (tensile force -  $F$ , the magnetic field -  $B$  and the critical current -  $I$ ) is used [16]. A new variable temperature insert is under construction to perform tensile load testing. The main parameters are the following:  $I_{\max} = 10 \text{ kA}$ ;  $B_{\max} = 12 \text{ T}$ ;  $F_{\max} = 100 \text{ kN}$ .

Especially high temperature superconducting cables are of interest with respect to power and magnet applications [17, 18].

## 6 Thermal properties

### 6.1 The Thermal Conductivity

The thermal conductivity is measured with the axial heat flow method within the *Physical Property Measurement System of Quantum Design* using a Thermal Transport Option in the steady-state measurement mode [19]. The temperature of the sample is driven to the required temperature point within temperature range from 1.9 K up to 300 K. Then the sample, which is connected to the thermal sink with constant temperature, is heated with constant heater power, and the temperature drop is measured along the sample with two *Cernox* temperature sensors, calibrated every year.

The geometry of the sample depends on thermal conductivity value at room temperature and is being adjusted for every material to ensure optimal measurement configuration and minimum heat losses from the sample surface. The software is estimating heat losses due to irradiation from the sample surface and due to heat flow from thermometer shoes contact wires. These are taken into account when calculating thermal conductivity value from values of heating power and temperature drop through the sample.

### 6.2 The Thermal Expansion Measurement

Thermal expansion measurements are performed in the temperature range from 4.5 K up to 290 K in GFRP (glass fibre reinforced plastic) liquid He-bath cryostat [19]. For sample dilatation measurements clip-on extensometers are used. Two extensometers made from copper–beryllium alloy are clipped directly on the sample. The two extensometer frames with four strain gauges compose a full Wheatstone bridge of 350 Ohm strain gauges, calibrated prior to every series of measurements. A calibration factor of extensometer depends slightly on the temperature. Extensometers have been calibrated for few different temperatures, and then calibration points have been fitted with a polynomial function over the whole temperature range. A corresponding calibration factor is used at different temperatures.



Any length change of the sample results in a change of resistivity of the extensometer strain gauges, which gives the real deformation of the sample in millimeters via the calibration factor. After mounting the extensometers on a sample, the initial measurement distance is determined for every measurement using the calibration factor at room temperature.

The samples together with the mounted extensometers is placed then in the liquid He-bath cryostat and cooled down. The measurement is performed by slowly warming during evaporation of the liquid He, due to non-ideal insulating vacuum. During 12 h of warming up to 290 K the system is in thermal equilibrium in the whole temperature range.

### Conclusions

Different kinds of cryogenic tests possible in a temperature range from RT down to 4.2 K at the CryoMaK laboratory were shown. For the mechanical tests a basic division is done regarding quasi static and dynamic tests. Standard tensile tests, fatigue tests, fracture toughness tests, instrumented impact tests, hardness, tests of components and non-standard tests can be performed. New devices, such as *MTS 100*, *Galdabini 450*, *INSTRON CEAST 9350* and *INNOVATEST NEXUS 4302* which became a part of CryoMaK in 2014, widen the scope of test possibilities.

Building an expertise in relation to material testing at low temperatures during the last years, the knowledge of basic material properties is getting higher priority. Together with basic material analysis as with the Bruker Q4 TASMEN 130, additional structural assessment with SEM, EBSD and x-ray, material behaviour can be characterized systematically.

### References

- [1] E.B. Graham: Cryogenics, Vol. 13, 1973, p. 453-456; DOI:10.1016/0011-2275(73)90001-5
- [2] D.F. Liu et al.: Journal of Iron and Steel Research, Vol. 21, 2009, p. 1-5
- [3] B. Collaudin, N. Rando: Cryogenics in Space, Vol. 40, 2000, p. 797-819; DOI:10.1016/S0011-2275(01)00035-2
- [4] R. Jedamzik, T. Westerhoff: Advances in Optical and Mechanical Technologies for Telescopes and Instrumentation, 2014, 91512P; DOI:10.1117/12.2055086
- [5] E.R. Gizewski, C. Mönninghoff, M. Forsting: Clinical Neuroradiology, Vol. 25, 2015, p. 267-273; DOI:10.1007/s00062-015-0437-4
- [6] S. Sharifzadeh, D. Verstraete, P. Hendrick: International Journal of Hydrogen Energy, Vol. 40, 2015, p. 12798-12810; DOI:10.1016/j.ijhydene.2015.07.120
- [7] M. Strano, P. Albertelli, E. Chiappini, S. Tirelli: International Journal of Material Forming, Vol. 8, 2015, p. 601-611; DOI:10.1007/s12289-014-1215-6
- [8] S. Yamaguchi, H. Koshizuka, K. Hayashi, T. Sawamura: Applied superconductivity, IEEE Transactions on, Vol. 25, 2015, p 1-4; DOI:10.1109/TASC.2015.2390045
- [9] N. Mitchell et al.: Fusion Engineering and Design, Vol. 84, 2009, p. 113-121; DOI:10.1016/j.fusengdes.2009.01.006
- [10] E. Pardo, M. Staines, Z. Jiang, N. Glasson: Superconductor Science and Technology, Vol. 28, 2015, art. no. 114008; DOI:10.1088/0953-2048/28/11/114008
- [11] H. Kojima, T. Osawa, N. Hayakawa: Applied superconductivity, IEEE Transactions on, Vol. 25, 2015, art. no. 7010877; DOI:10.1109/TASC.2015.2392251
- [12] V.S. Chakravarthy, R.K. Shah, G.A. Venkatarathnam: Journal of Thermal Science and Engineering Applications, Vol. 3, 2011, art. no. 020801; DOI:10.1115/1.4003701



- [13] A. Nyilas: Advances in Cryogenic Engineering: Trans. International Cryogenic Materials Conference- ICMC, Vol. 52, 2006, p. 27–34; DOI:10.1063/1.2192330
- [14] A. Nyilas: Superconductor Science and Technology, Vol. 18, 2005, p 409-415; DOI:10.1088/0953-2048/18/12/031
- [15] N. Bagrets, E. Weiss, S. Westenfelder, K.-P. Weiss: Applied superconductivity, IEEE Transactions on, Vol. 22, 2012, art. no 9501204; DOI:10.1109/TASC.2011.2176902
- [16] C. Bayer, C. Barth, P.V. Gade, K.-P. Weiss, R. Heller: Applied superconductivity, IEEE Transactions on, Vol. 24, 2014, art. no. 9500604; DOI:10.1109/TASC.2013.2287710
- [17] C. Barth, D.C. Van Der Laan, N. Bagrets, C.M. Bayer, K.-P. Weiss, C. Lange: Superconductor Science and Technology, Vol. 28, 2015, art. no. 065007; DOI:10.1088/0953-2048/28/6/065007
- [18] C. Barth, M. Takayasu, N. Bagrets, C.M. Bayer, K.-P. Weiss, C. Lange: Superconductor Science and Technology, Vol. 28, 2015, art. no. 045015; DOI:10.1088/0953-2048/28/4/045015
- [19] N. Bagrets, W. Goldacker, S.I. Schlachter, C. Barth, K.-P. Weiss: Cryogenics 61, 2014, p. 8-14, DOI:10.1016/j.cryogenics.2014.01.015